



# LEVEL CONTROL SUPPLYING WATER TO ELEVATED TANK

## HIGHLIGHTS

- Maintain precise and repeatable tank level of drinking water
- Use of a smart metering valve with flow, pressure and temperature measurement, control valve and extensive computing power in one device
- Cavitation diagnostics prevent damage caused by spontaneous pressure load
- Energy and cost-saving operation; high savings potential for emergency power supply

### 1. BACKGROUND

A municipal utility in eastern Germany operates two water towers for the drinking water supply of adjacent communities. The stored water comes from different water treatment plants and meets the high-quality requirements for drinking water in Germany. While the water complies with all current limits, it has a high degree of hardness due to the high lime content. As a result, the plan is to switch the water source to a remote reservoir connected via a long-distance pipeline.

### 2. CONTROL REQUIREMENTS

The long-distance pipeline (DN300) is operated at a pressure of 10...13 bar / 145...188.5 psi. The operator must regulate the supply to the elevated tanks to achieve the desired tank level setpoint and the pressure at the inlet must be carefully controlled so that no damage occurs to the components due to excessive differential pressures. Damage to the infrastructure in such applications had so far been prevented by the combined use of piston actuated control valves, flow and level instrumentation and process automation. Another risk factor is cavitation. The implosion of cavitating gas bubbles can lead to localized pressure spikes that can cause considerable damage. This drinking water supplier was looking for a simple and more cost-effective solution that could also be operated in emergency situations with significantly less power. Maintaining emergency power capacity is a significant cost factor in the water industry, so a conventional electric actuated control valve that requires 3-4 kW was not an option. The customer preferred a pneumatic control valve with a maximum power consumption of around 15 W.

### 3. FOCUS-ON SOLUTION

This drinking water supplier has decided in favour of using the FOCUS-1 smart meter valve. The unit combines sensors, actuators and a control valve. Setpoints for control of pressure, flow rate or external control variables can all be set in one device. In this application FOCUS-1 reliably controls the level as an external control variable according to the desired setpoint.

Unlike electric valve actuators, the actuator of the FOCUS-1 works pneumatically. It therefore operates in an energy-saving manner and only requires a constant supply of compressed air. Equipped with integrated compressed air preparation, those pneumatic actuators have been operating maintenance-free and leak-free in the water industry for many years. The operator can set the PID behaviour of the controller individually or automatically.

By way of a calculation based on the minimum and maximum flow rate and the differential pressure, the meter valve can be designed in such a way that the control valve and the inlet are outside the cavitation area at all times. Thanks to its sophisticated algorithms, the intelligent measuring valve can also create a "digital twin" so that device function and operation can be maintained even in the unlikely event of a sensor failure. The customer reproduces all the data from the measuring valve in its control system. The transmission of all relevant process data via PROFINET enables condition-based maintenance. All sensors can be replaced if necessary.

The wetted components of the measuring valve are primarily made of stainless steel and are safe for use with drinking water. The seal for the pressure and temperature sensor is made of EPDM and approved for drinking water applications.

#### 4. CUSTOMER BENEFITS

FOCUS-1 enables a smart and efficient water tank management. The computer-based communication of the internal components for valve control, flow and pressure as well as the internal PID controller allow for reliable and accurate control of the tank level, which is provided as an external measurement signal in the FOCUS-1. Even cavitation-related stress on the valve and pipework can be detected at an early stage. The integrated cavitation and device diagnostics can effectively prevent unplanned system downtime. Thanks to the redundant flow measurement, FOCUS-1 is also able to detect valve seat wear and thus leakage.

The use of the FOCUS-1 unlocks potential for considerable savings in operating costs. Thanks to the pneumatic actuator, the FOCUS-1 can be operated in a much more energy-efficient manner, especially in the event of power outage or shut-offs. This is because maintaining pressure compression for two days is significantly cheaper than storing electricity for the same period. Even with regard to the investment in these emergency power generators, potential savings in the five-digit euro range are in the realm of possibilities. Operating the FOCUS-1 requires little power and therefore pays off right after commissioning.

#### 5. PRODUCT USED

- Smart meter valve for flow, pressure and process control
- Integrated control valve, flowmeter, pressure and temperature sensors combined with extensive computing power in one single device
- Full process control on valve positioning, flowrate, pressure or external process parameters with unique diagnostics
- Seamless integration into all automation systems, e.g. 4...20 mA, HART®, PROFINET, Ethernet or Wi-Fi
- Simple engineering, installation and operation whilst increasing control quality and plant uptime
- Also available with integrated totaliser for continues water usage registration.

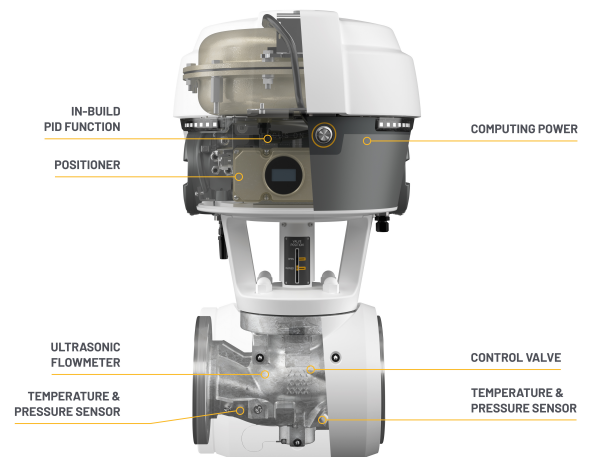

#### FOCUS-ON VoF

Kerkeplaat 12  
3313 LC Dordrecht  
the Netherlands

Tel.: +31 682633713  
info@fon-p.com  
focus-on-process.com

WANT TO LEARN MORE ABOUT  
HOW FOCUS-1 IS USED?  
**SCAN THIS QR-CODE**



website